

R-102 RESTAURANT FIRE SUPPRESSION SYSTEMS DATA SHEET

R-102 Restaurant Fire Suppression Systems



Features

- Low pH Agent
- Proven Design
- Reliable Gas Cartridge Operation
- Aesthetically Appealing
- UL Listed – Meets Requirements of UL 300
- ULC Listed – Meets Requirements of ULC/ORD-C1254.6
- CE Marked

Application

The ANSUL® R-102 Restaurant Fire Suppression System is an automatic, pre-engineered, fire suppression system designed to protect areas associated with ventilating equipment including hoods, ducts, plenums, and filters. The system also protects auxiliary grease extraction equipment and cooking equipment such as fryers; griddles and range tops; upright, natural charcoal, or chain-type broilers; electric, lava rock, mesquite, or gas radiant char broilers; and woks.

The system is ideally suitable for use in restaurants, hospitals, nursing homes, hotels, schools, airports, and other similar facilities.

Use of the R-102 system is limited to indoor applications or locations that provide weatherproof protection within tested temperature limitations. The regulated release and tank assemblies must be mounted in an area where the air temperature will not fall below 32 °F (0 °C) or exceed 130 °F (54 °C). The system must be designed and installed within the guidelines of the UL/ULC Listed Design, Installation, Recharge, and Maintenance Manual.

System Description

The restaurant fire suppression system is a pre-engineered, wet chemical, cartridge-operated, regulated pressure type with a fixed nozzle agent distribution network. It is listed with Underwriters Laboratories (UL/ULC).



004215

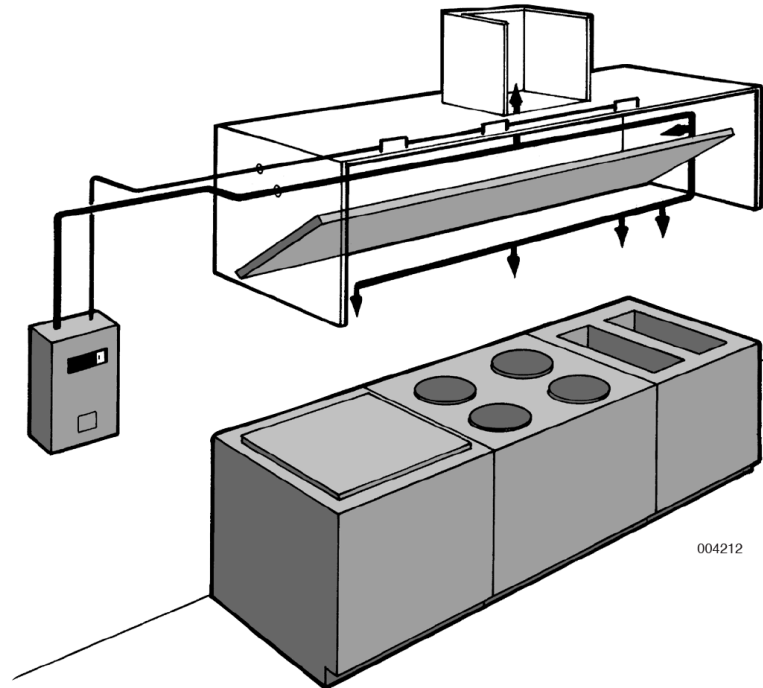

004212

The system is capable of automatic detection and actuation as well as remote manual actuation. Additional equipment is available for building fire alarm panel connections, electrical shut-down and/or interface, and mechanical or electrical gas line shut-off applications.

The detection portion of the fire suppression system allows for automatic detection by means of specific temperature-rated alloy type fusible links, which separate when the temperature exceeds the rating of the link, allowing the regulated release to actuate.

A system owner's guide is available containing basic information pertaining to system operation and maintenance. A detailed technical manual, including system description, design, installation, recharge and resetting instructions, and maintenance procedures, is available to qualified individuals.

The system is installed and serviced by authorized distributors that are trained by the manufacturer.

The basic system consists of an AUTOMAN regulated release assembly which includes a regulated release mechanism and a wet chemical storage tank housed within a single enclosure. Nozzles with blow-off caps, detectors, cartridges, agent, and pulley elbows are supplied in separate packages in the quantities needed for fire suppression system arrangements.

Additional equipment includes a remote manual pull station(s), mechanical and electrical gas valves, and electrical switches for automatic equipment and gas line shut-off. Accessories can be added such as alarms, warning lights, etc., to installations where required.

Additional tanks and corresponding equipment can be used in multiple arrangements to allow for larger hazard coverage. Each tank is limited to a listed maximum amount of flow numbers.





009368

Component Description

Wet Chemical Agent – The extinguishing agent is a mixture of organic salts designed for rapid flame knockdown and foam securement of grease related fires. It is available in plastic containers with instructions for wet chemical handling and usage.

Agent Tank – The agent tank is installed in a stainless steel enclosure or wall bracket. The tank is constructed of stainless steel.

Tanks are available in two sizes: 1.5 gallon (5.7 L) and 3.0 gallon (11.4 L). The tanks have a working pressure of 110 psi (7.6 bar), a test pressure of 330 psi (22.8 bar), and a minimum burst pressure of 660 psi (45.5 bar).

The tank includes an adaptor/tube assembly. The adaptor assembly includes a chrome-plated steel adaptor with a 1/4 in. NPT female gas inlet, a 3/8 in. NPT female agent outlet, and a stainless steel agent pick-up tube. The adaptor also contains a bursting disc seal which helps to prevent the siphoning of agent up the pipe during extreme temperature variations.

Regulated Release Mechanism – The regulated release mechanism is a spring-loaded, mechanical/pneumatic type capable of providing the expellant gas supply to one, two, or three agent tanks depending on the capacity of the gas cartridge used. It contains a factory installed regulator deadset at 110 psi (7.6 bar) with an external relief of approximately 180 psi (12.4 bar). It has automatic actuation capabilities by a fusible link detection system and remote manual actuation by a mechanical pull station.

The regulated release mechanism contains a release assembly, regulator, expellant gas hose, and agent storage tank housed in a stainless steel enclosure with cover. The enclosure contains knock-outs for 1/2 in. conduit. The cover contains an opening for a visual status indicator.

It is compatible with mechanical gas shut-off devices; or, when equipped with a field or factory-installed switch and manual reset relay, it is compatible with electric gas line or appliance shut-off devices.

Regulated Actuator Assembly – When more than two agent tanks (or three 3.0 gallon (11.4 L) tanks in certain applications) are required, the regulated actuator is available to provide expellant gas for additional tanks. It is connected to the cartridge receiver outlet of the regulated release mechanism providing simultaneous agent discharge. It contains a regulator deadset at 110 psi (7.6 bar) with an external relief of approximately 180 psi (12.4 bar). It has automatic actuation capabilities using pressure from the regulated release mechanism cartridge.

The regulated actuator assembly contains an actuator, regulator, expellant gas hose, and agent tank housed in a stainless steel enclosure with cover. The enclosure contains knockouts to permit installation of the expellant gas line.

Discharge Nozzles – Each discharge nozzle is tested and listed with the R-102 system for a specific application. Nozzle tips are stamped with the flow number designation (1/2, 1, 2, or 3). Each nozzle must have a metal or rubber blow-off cap to keep the nozzle tip orifice free of cooking grease build-up.

Agent Distribution Hose – Kitchen appliances manufactured with or resting on casters (wheels/rollers) may include an agent distribution hose as a component of the suppression system. This allows the appliance to be moved for cleaning purposes without disconnecting the appliance fire suppression protection. The hose assembly includes a restraining cable kit to limit the appliance movement within the range (length) of the flexible hose.

Flexible Conduit – Flexible conduit allows for quicker installations and the convenience of being able to route the cable over, under and around obstacles. Flexible conduit can be used as a substitute for standard EMT conduit or can be used with EMT conduit. Flexible conduit can be used only with the Molded Remote Manual Pull Station and with the Mechanical Gas Valve Assembly.

Pull Station Assembly – The remote manual pull station is made out of a molded red composite material. The red color makes the pull station more readily identifiable as the manual means for fire suppression system operation. The pull station is compatible with the ANSUL Flexible Conduit and with 1/2 in. EMT conduit.

Approvals

- UL/ULC Listed
- CE Marked
- New York City Department of Buildings – COA #5663
- LPCB
- TFRI
- Marine Equipment Directive (MED)
- DNV
- ABS
- Lloyd's Register
- Meets requirements of NFPA 96 (Standard for the Installation of Equipment for the Removal of Smoke and Grease-Laden Vapors from Commercial Cooking Equipment)
- Meets requirements of NFPA 17A (Standard on Wet Chemical Extinguishing Systems)

Ordering Information

Order all system components through your local authorized ANSUL Distributor.

Specifications

An ANSUL R-102 Fire Suppression System shall be furnished. The system shall be capable of protecting all hazard areas associated with cooking equipment.

1.0 GENERAL

1.1 References

- 1.1.1 Underwriters Laboratories (UL)
 - 1.1.1.1 UL Standard 1254
 - 1.1.1.2 UL Standard 300
- 1.1.2 Underwriters Laboratories of Canada (ULC)
 - 1.1.2.1 ULC/ORD-C 1254.6
- 1.1.3 National Fire Protection Association (NFPA)
 - 1.1.3.1 NFPA 96
 - 1.1.3.2 NFPA 17A

1.2 Submittals

- 1.2.1 Submit two sets of manufacturer's data sheets
- 1.2.2 Submit two sets of piping design drawings

1.3 System Description

- 1.3.1 The system shall be an automatic fire suppression system using a wet chemical agent for cooking grease related fires.
- 1.3.2 The system shall be capable of suppressing fires in the areas associated with ventilating equipment including hoods, ducts, plenums, and filters as well as auxiliary grease extraction equipment. The system shall also be capable of suppressing fires in areas associated with cooking equipment, such as fryers; griddles and range tops; upright, natural charcoal, or chain-type broilers; electric, lava rock, mesquite or gas-radiant char-broilers; and woks.
- 1.3.3 The system shall be the pre-engineered type having minimum and maximum guidelines established by the manufacturer and listed by Underwriters Laboratories (UL/ULC).
- 1.3.4 The system shall be installed and serviced by personnel trained by the manufacturer.
- 1.3.5 The system shall be capable of protecting cooking appliances by utilizing either dedicated appliance protection and/or overlapping appliance protection.

1.4 Quality Control

- 1.4.1 Manufacturer: The R-102 Restaurant Fire Suppression System shall be manufactured by a company with at least forty years experience in the design and manufacture of pre-engineered fire suppression systems. The manufacturer shall be ISO 9001 registered.
- 1.4.2 Certificates: The wet agent shall be a specially formulated, aqueous solution of organic salts with a pH range between 7.7 – 8.7, designed for flame knockdown and foam securement of grease-related fires.

1.5 Warranty, Disclaimer, and Limitations

1.5.1 The pre-engineered restaurant fire suppression system components shall be warranted for five years from date of delivery against defects in workmanship and material.

1.6 Delivery

1.6.1 Packaging: All system components shall be securely packaged to provide protection during shipment.

1.7 Environmental Conditions

1.7.1 The R-102 system shall be capable of operating within a temperature range of 32 °F to 130 °F (0 °C to 54 °C).

2.0 PRODUCT

2.1 Manufacturer

2.1.1 Johnson Controls, One Stanton Street, Marinette, Wisconsin 54143-2542, Telephone (715) 735-7411.

2.2 Components

- 2.2.1 The basic system shall consist of an AUTOMAN regulated release assembly which includes a regulated release mechanism and a wet chemical storage tank housed within a single enclosure. Nozzles, blow-off caps, detectors, cartridges, agent, fusible links, and pulley elbows shall be supplied in separate packages in the quantities needed for fire suppression system arrangements. Additional equipment shall include remote manual pull station, mechanical and electrical gas valves, and electrical switches for automatic equipment and gas line shut-off, and building fire alarm control panel interface.
- 2.2.2 Wet Chemical Agent: The extinguishing agent shall be a specially formulated, aqueous solution of organic salts with a pH range between 7.7 – 8.7, designed for flame knockdown and foam securement of grease related fires.
- 2.2.3 Agent Tank: The agent tank shall be installed in a stainless steel enclosure or wall bracket. The tank shall be constructed of stainless steel. Tanks shall be available in two sizes; 1.5 gallon (5.7 L) and 3.0 gal (11.4 L). The tank shall have a working pressure of 110 psi (7.6 bar), a test pressure of 330 psi (22.8 bar), and a minimum burst pressure of 660 psi (45.5 bar). The tank shall include an adaptor/tube assembly containing a burst disc union.

Specifications (Continued)

- 2.2.4 Regulated Release Mechanism: The regulated release mechanism shall be a spring-loaded, mechanical/pneumatic type capable of providing the expellant gas supply to one or two agent tanks depending on the capacity of the gas cartridge used or three 3.0 gallon (11.4 L) agent storage tanks in certain applications. It shall contain a factory installed regulator deadset at 110 psi (7.6 bar) with an external relief of approximately 180 psi (12.4 bar).
- It shall have the following actuation capabilities: automatic actuation by a fusible link detection system and remote manual actuation by a mechanical pull station.
- The regulated release mechanism shall contain a release assembly, regulator, expellant gas hose, and agent storage tank housed in a stainless steel enclosure with cover. The enclosure shall contain knock-outs for 1/2 in. conduit. The cover shall contain an opening for a visual status indicator.
- It shall be compatible with mechanical gas shutoff devices; or, when equipped with a field or factory-installed switch(es), it shall be compatible with electric gas line or appliance shut-off devices, or connections to a building fire alarm control panel.
- 2.2.5 Regulated Actuator Assembly: When more than two agent tanks or three agent tanks in certain applications are required, the regulated actuator shall be available to provide expellant gas for additional tanks. It shall be connected to the cartridge receiver outlet of the regulated release mechanism providing simultaneous agent discharge. The regulator shall be deadset at 110 psi (7.6 bar) with an external relief of approximately 180 psi (12.4 bar).
- The regulated actuator assembly shall contain an actuator, regulator, expellant gas hose, and agent tank housed in a stainless steel enclosure with cover. The enclosure shall contain knockouts to permit installation of the expellant gas line.
- 2.2.6 Discharge Nozzles: Each discharge nozzle shall be tested and listed with the R-102 system for a specific application. Nozzles tips shall be stamped with the flow number designation (1/2, 1, 2, or 3). Each nozzle shall have a metal or rubber blow-off cap to keep the nozzle tip orifice free of cooking grease build-up.
- 2.2.7 Distribution Piping: Distribution piping shall be Schedule 40 black iron, chrome-plated, or stainless steel conforming to ASTM A120, A53, or A106.
- 2.2.8 Detectors: The detectors shall be the fusible link style designed to separate at a specific temperature, or shall be electric thermal detectors designed to operate at a factory preset temperature.
- 2.2.9 Cartridges: The cartridge shall be a sealed steel pressure vessel containing either carbon dioxide or nitrogen gas. The cartridge seal shall be designed to be punctured by the releasing device supplying the required pressure to expel wet chemical agent from the storage tank.

- 2.2.10 Agent Distribution Hose: An optional agent distribution hose shall be available for kitchen appliances manufactured with or resting on casters (wheels/rollers). This shall allow the appliance to be moved for cleaning purposes without disconnecting the appliance fire suppression protection. Hose assembly shall include a restraining cable kit to limit the appliance movement within the range (length) of the flexible hose.
- 2.2.11 Flexible Conduit: The manufacturer supplying the Restaurant Fire Suppression System shall offer flexible conduit as an option to rigid EMT conduit for the installation of pull stations and/or mechanical gas valves. The flexible conduit shall be UL Listed and include all approved components for proper installation.
- 2.2.12 Pull Station Assembly: The Fire Suppression System shall include a remote pull station for manual system actuation. The pull station shall be designed to include a built-in guard to protect the pull handle. The pull station shall also be designed with a pull handle to allow for three finger operation and shall be red in color for quick visibility.

3.0 IMPLEMENTATION

3.1 Installation

- 3.1.1 The R-102 fire suppression system shall be designed, installed, inspected, maintained, and recharged in accordance with the manufacturer's listed instruction manual.

3.2 Training

- 3.2.1 Training shall be conducted by representatives of the manufacturer.

Note: The converted values in this document are for dimensional reference only and do not reflect an actual measurement.

ANSUL, R-102, and the product names listed in this material are marks and/or registered marks. Unauthorized use is strictly prohibited.

Scan Me - Contact Us via QR Code

